

BORESITE BALL COUPLING



PART NO. 100 SERIES

SPECIFICATION:

- **PRESSURE:**
Inlet (Operating): 1000 PSIG
Proof: 1500 PSIG
Burst: 2500 PSIG (min.)
- **TEMPERATURE RANGE:**
Operating: -65 to +450°F
(-54 to +232°C)
- **MEDIUM:**
Water, nitrogen, nitrogen tetroxide, JP4, hydraulic fluid per MIL-H-5606 and lubricating oil per MIL-L-7808.

- **FLOW:**
Equivalent to 1.312 DIA.
Orifice (with end fittings as shown).
- **LEAKAGE:**
Coupled condition:
Internal – zero up to max. operating pressure.
External – zero up to max. operating pressure.
Uncoupled conditions:
Zero up to max. operating pressure.
- **WEIGHT:**
Aluminum alloy construction: 1.9 lbs. (max.)
Stainless steel construction: 3.5 lbs. (max.) (with end fittings as shown.)

OPERATION:

To couple: Insert nipple half into socket half, cover and twist clockwise approximately 1/4 turn.

To uncouple: Pull socket half cover and twist counterclockwise. Mating halves can be arranged to prevent inadvertent coupling of the same size disconnects used for different fluids.

MATERIALS:

Aluminum alloy and/or stainless steel, and elastomeric seal.

APPLICATIONS:

Used for rapid coupling and uncoupling of pressurized fluid transfer lines. Seals in each of the coupling halves, permits uncoupling with minimal spillage and zero subsequent leakage. Suitable for use in pneumatics, hydraulics and fluid transfer applications.

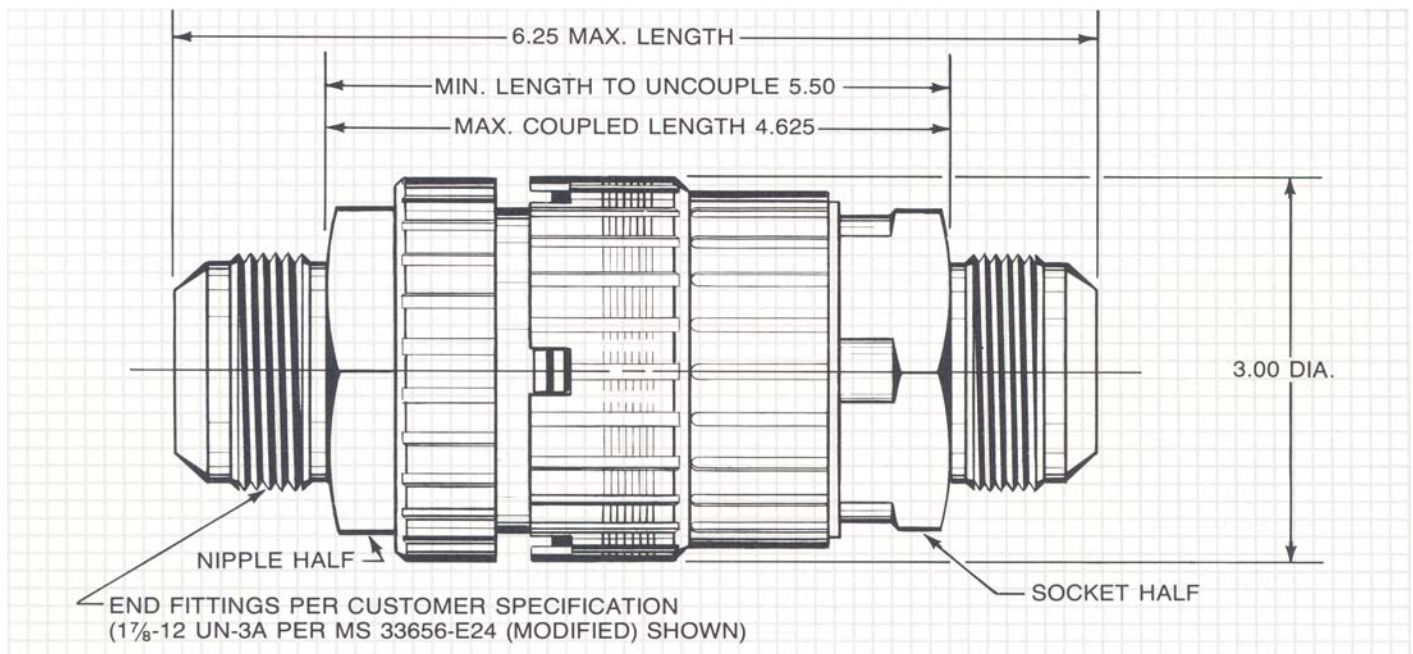

GENERAL PNEUMATICS
CORPORATION

www.gpcvalves.com

Corporate Headquarters
440 Washington Street
Orange, NJ 07050
Ph: 973-678-6555 FAX: 973-678-9632

Western Research Center
3616 W. Thomas Rd., Ste. 1
Phoenix, AZ 85019
Ph: 602-278-5678 FAX: 602-278-5614