

# GENERAL PNEUMATICS CORPORATION



## PART NO. 504 GPS SERIES

### SPECIFICATION:

- **PRESSURE:**  
Inlet (Operating): 1500 to 3500 PSIG  
Proof: 5000 PSIG  
Burst: 7500 PSIG (min.)
- **TEMPERATURE RANGE:**  
Operating: -65 to +160°F (-54 to +71°C)
- **MEDIUM:**  
Dry air and inert gases

## CABLE OPERATED BALL VALVE

- **FLOW:**  
Equivalent to .160 DIA. orifice
- **LEAKAGE:**  
Bubble tight up to maximum operating pressure
- **WEIGHT:**  
0.71 lb. (max.) without optional pressure gage (weight depends on model), gage protector shell (.19 lb), and siphon tube (.10 lb)
- **OPERATION:**  
To arm: Engage cable ball end in pulley and inert 3/16 hex key in pulley socket. Lift lock pin, rotate pulley counter-clockwise with hex key until pin aligns

with mark ▲, release lock pin. Detent will engage. To actuate: Pull cable. (Max. pull force required is 15 lbs.)

### MATERIALS:

Anodized aluminum, stainless steel, soft seat, and Buna-N

### APPLICATIONS:

Used when mechanical actuation or initiation of a pressure regulated gas flow is required. Typical applications include rapid inflation of life rafts and emergency slide evacuation systems for military and commercial aircraft.

**Note:** Other valve configurations with alternate feature orientations available upon request.

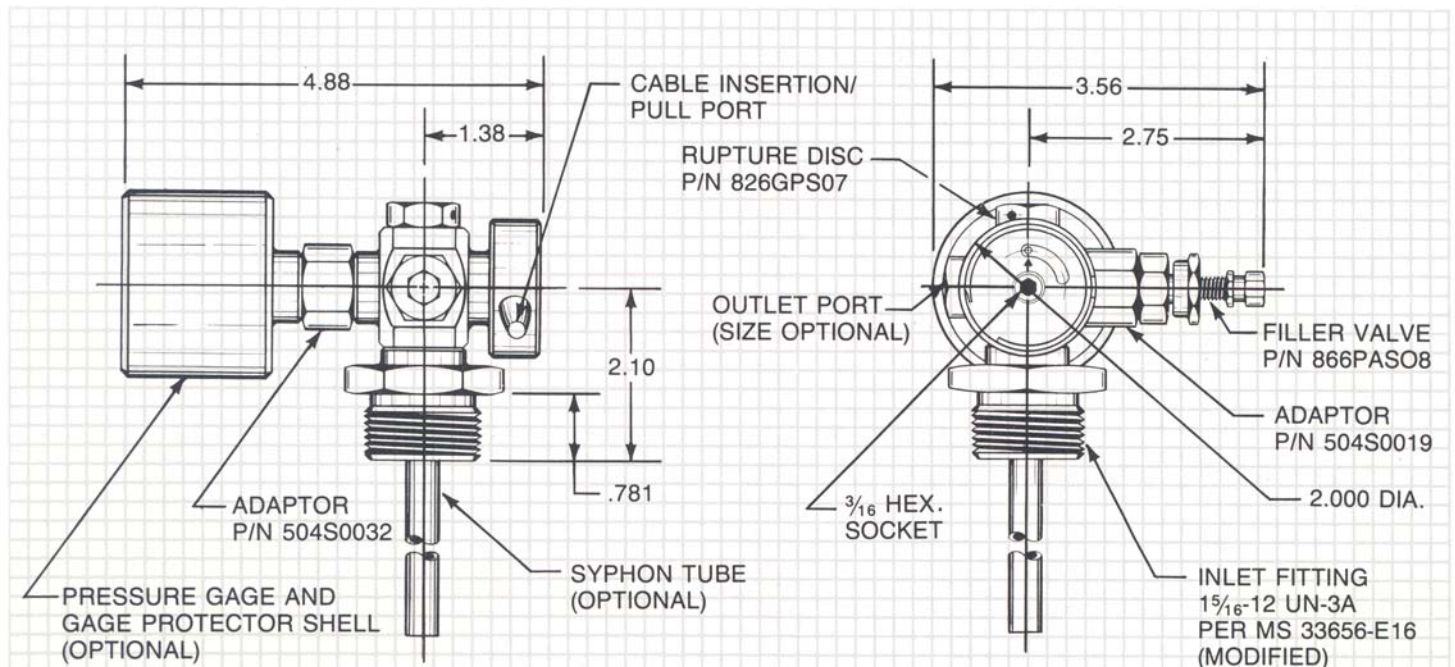

**GENERAL PNEUMATICS**  
CORPORATION

[www.gpcvalves.com](http://www.gpcvalves.com)

Corporate Headquarters  
440 Washington Street  
Orange, NJ 07050  
Ph: 973-678-6555 FAX: 973-678-9632

Western Research Center  
3616 W. Thomas Rd., Ste. 1  
Phoenix, AZ 85019  
Ph: 602-278-5678 FAX: 602-278-5614